

0086

BS EN ISO 9001



FM 00707

FLOWSERVE[®]

Worcester Controls

C44

Cryogenic 3-Piece Ball Valves

Cryogenic Valve Design

Worcester's experience and expertise in the design of cryogenic ball valves has been recognised throughout the process industry for over 30 years. Utilising a combination of our Fluorofill seat material and our unique 'S' gasket body seal, the valve provides positive shut-off in the most demanding of cryogenic applications. From the original C44 R5 and MC44 designs the seat and body seals have remained a constant feature and with both products now rationalised into the C44 R7, additional technical advantages have been included to provide the best cryogenic ball valve on the market.

The Worcester 3-piece ball valve offers a number of technical advantages over other types of valve.

High Flow Rate

The high Cv available from a ball valve compared with a globe valve makes the C44 ideal for loading stations where speed of delivery is critical. The valve is also available as fullbore up to DN40 as the C59 series.

Low Body Mass

The one-piece design minimises the mass of the body and therefore makes the valve economic to use. It also provides a weight advantage, making the valve ideal for road tankers and other transportation requirements.

Ease of Operation

The unique low torque seat design and the 90 degree operation of the ball valve makes it ideal for use with both pneumatic and electric actuators with the additional benefit of rotary control if required. When manually operated, the lever provides visual indication of the valve orientation (open or closed) which is critical in the safe loading and unloading of liquid gases.

Ease of Maintenance

The 3-piece concept provides the benefit of easy maintenance through the "slide out" body method.

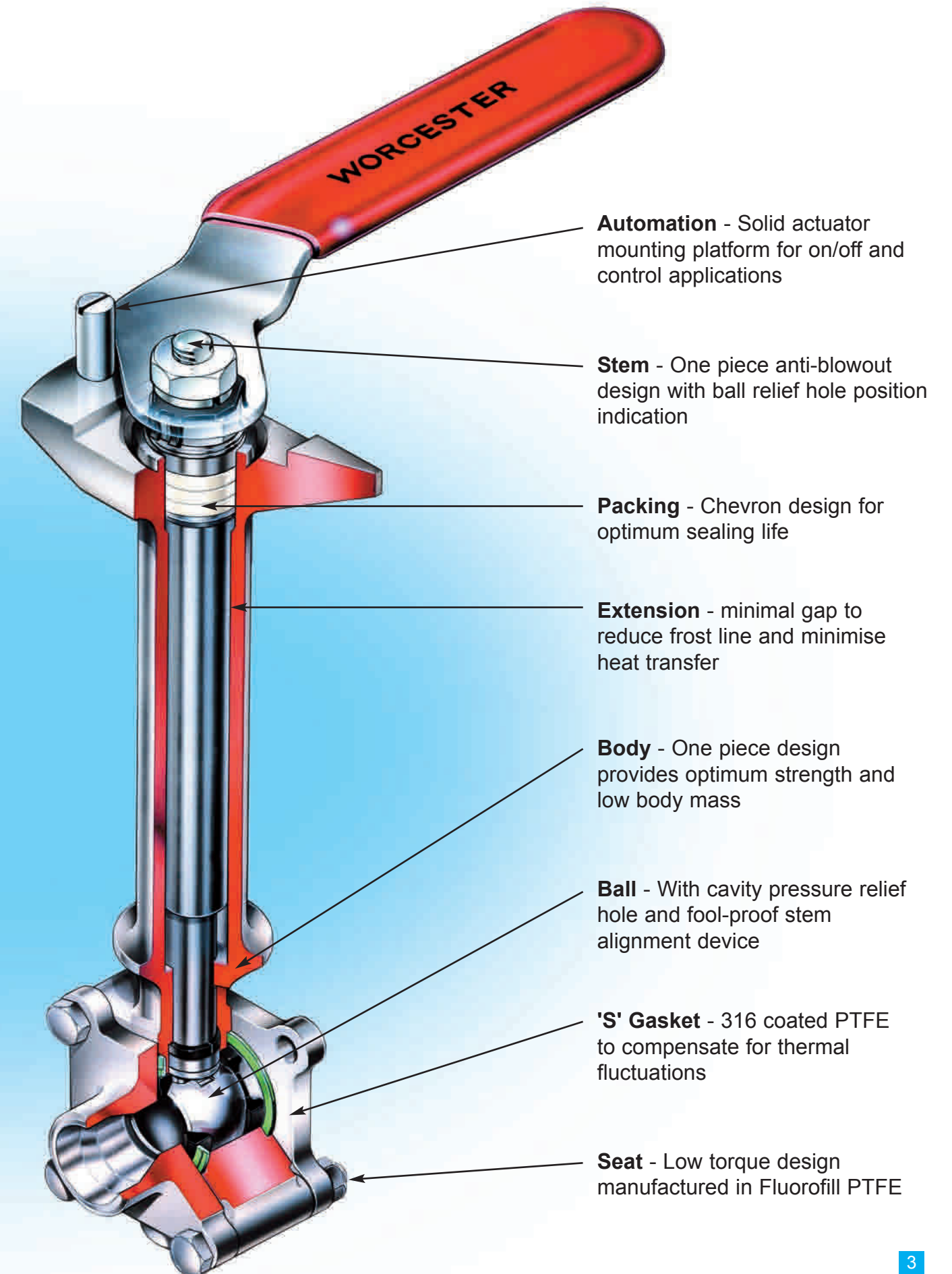

Automation - Solid actuator mounting platform for on/off and control applications

Stem - One piece anti-blowout design with ball relief hole position indication

Packing - Chevron design for optimum sealing life

Extension - minimal gap to reduce frost line and minimise heat transfer

Body - One piece design provides optimum strength and low body mass

Ball - With cavity pressure relief hole and fool-proof stem alignment device

'S' Gasket - 316 coated PTFE to compensate for thermal fluctuations

Seat - Low torque design manufactured in Fluorofill PTFE

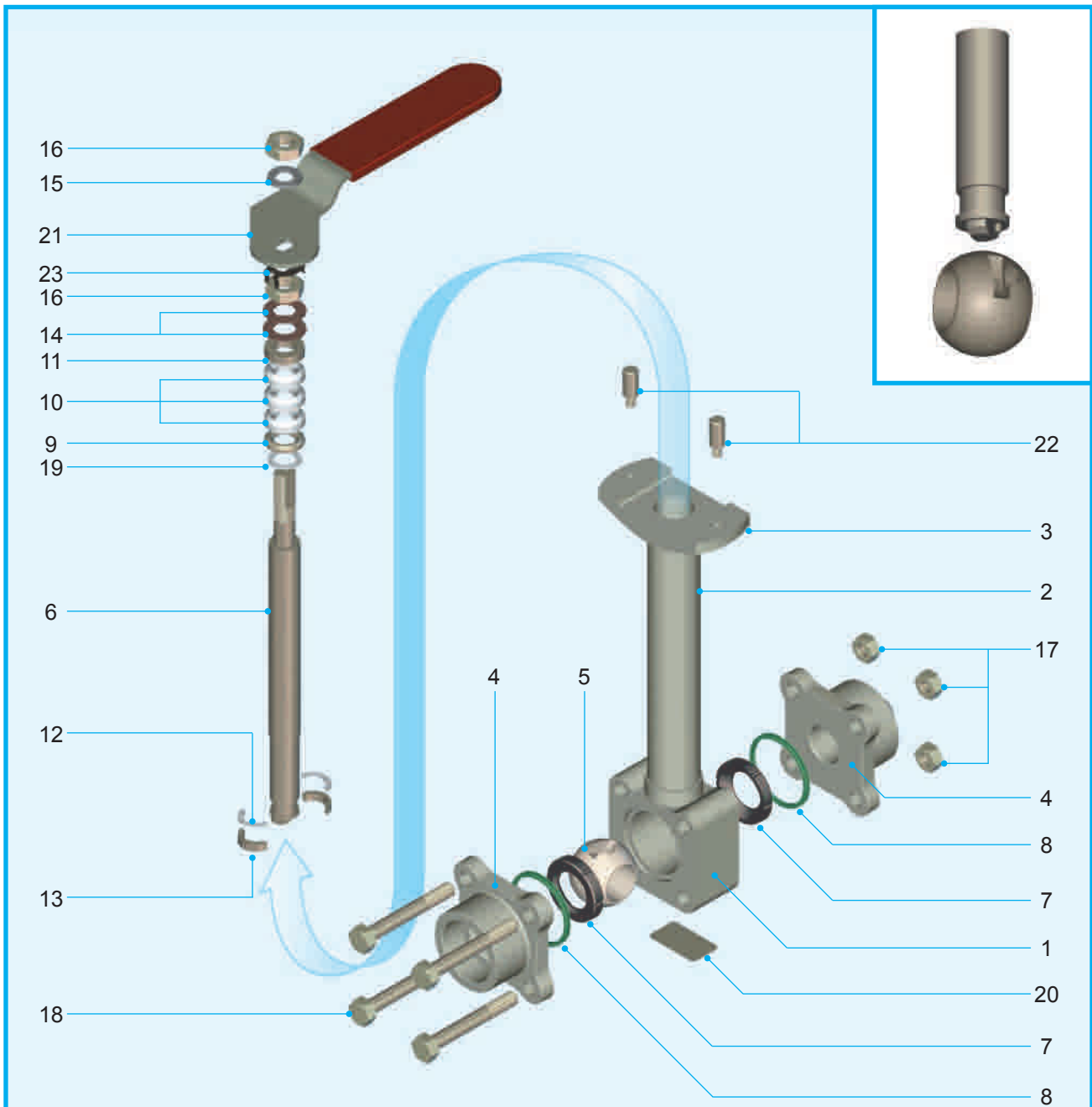

PARTS/MATERIALS LIST

ITEM	DESCRIPTION	MATERIAL	ITEM	DESCRIPTION	MATERIAL
1.	Body	Stainless Steel ASTM A351/CF3M Brass ASTM B283 C37700	12.	Split Thrust Bearing	Polyfill
2.	Extension	Stainless Steel ASTM A312/316L	13.	Split Ring (Halves)	Stainless Steel ASTM A479/316L
3.	Bonnet Plate	Stainless Steel ASTM A743/CF3M	14.	Belleville Washer	Stainless Steel AISI 301
4.	Pipe End	Stainless Steel ASTM A351/CF3M Brass BS2872 CZ122	15.	Spring Washer	Stainless Steel AISI 300 Series
5.	Ball	St. Steel ASTM A479/316 Cond. A	16.	Stem & Handle Nut	St. Steel AISI 300 Series/Zinc Plated
6.	Stem Assembly	St. Steel ASTM A479/316 Cond. A	17.	Body Nut	Stainless Steel ASTM A194 Gr.8
7.	Seat	Fluorofill	18.	Body Bolt	St. Steel ASTM A193 Gr.B8/ENP
8.	Body Seal	Stainless Steel AISI 316/TFE Coated	19.	Thrust Bearing	Fluorofill
9.	Packing Follower (Bottom)	Stainless Steel ASTM A479/316L	20.	Nameplate	Stainless Steel AISI 304
10.	Packing Ring	Crane Chemlon V-Ring/Teflon	21.	Wrench/Sleeve Assembly	St. Steel AISI 300 Series/Vinyl Coated
11.	Packing Follower (Top)	Stainless Steel ASTM A479/316L	22.	Stop Pin	Stainless Steel AISI 300 Series
			23.	Locking Clip	Carbon Steel Plated

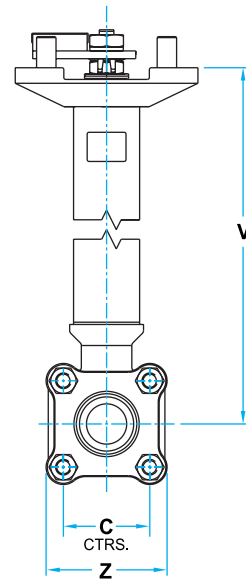
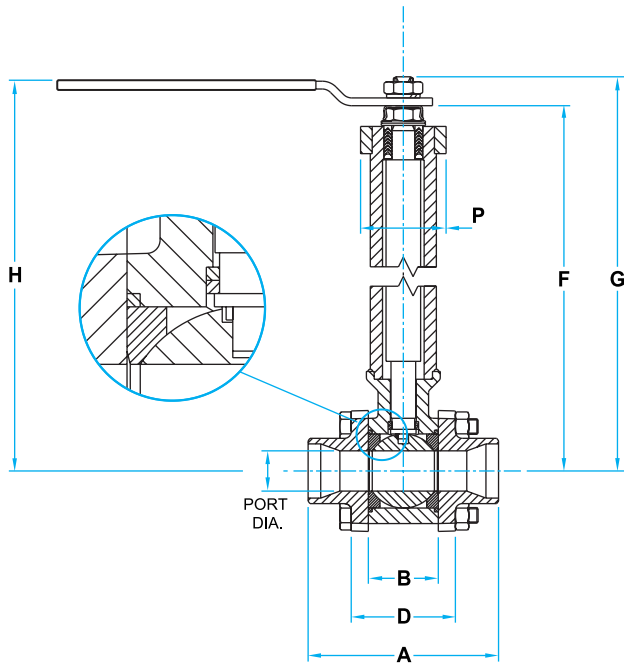
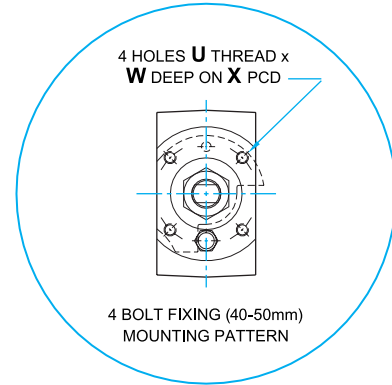
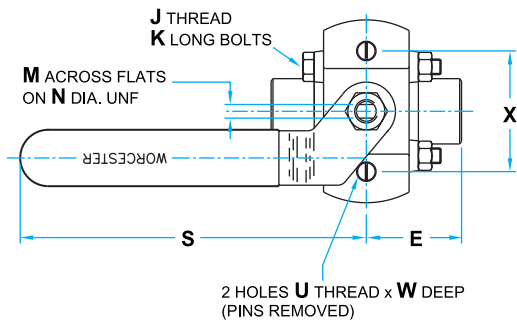

VALVE DIMENSIONS

Valve Size (mm)	Port Dia.	A	B	C	D	E	F	G	H	J	K	M Max.	N	S	U	V	W	X	Z	Approx. Weight (kg)
15	11.1	65.4	20.58	31.8	31.8	32.7	184.21	199.64	199.9	M6	40	7.5	7/16-20	165.1	M6	175.8	9.5	63.5	47.6	1.4
20	14.3	71.0	24.55	38.1	37.4	35.5	186.75	202.5	202.5	M6	45	7.5	7/16-20	165.1	M6	178.3	9.5	63.5	54.4	1.6
25	20.6	93.7	31.69	44.5	49.3	46.9	201.88	226.31	227.1	M8	60	7.5	7/16-20	165.1	M6	202.5	9.7	63.5	65.4	2.3
40	31.8	114.6	48.35	57.2	69.6	57.3	241.83	259.84	264.8	M10	80	8.67	9/16-18	181.0	M6	230.9	8.7	50.0	80.3	5.0
50	38.1	127.1	56.28	66.7	79.1	63.6	246.40	264.41	269.4	M10	90	8.67	9/16-18	181.0	M6	235.5	8.7	50.0	90.4	5.9

THROTTLING CONTROL OF CRYOGENICS

The Worcester V-Flow provides positive shut-off with accurate control by utilising a cryogenic flourofill seat downstream and a metal profiled seat upstream. The choice of seat profile on the upstream seat is dependent on the flow conditions required. The V-Flow is ideally suited for either electric actuation using a 75 series Norbro DataFlo P or pneumatic 40R series with a PMV positioner.

The combination of the V-Flow with the cryogenic C44 design provides an ideal cryogenic control valve for a variety of applications from food freezing to high purity gases.

UPSTREAM SEAT SELECTION

(SOME TYPICAL EXAMPLES)

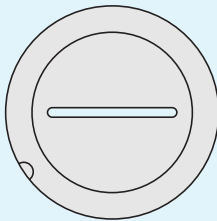

Slotted Seat
(linear characteristic)

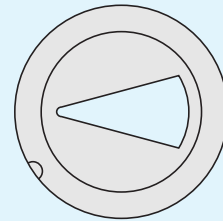
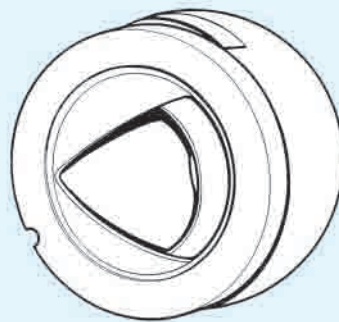

30° Seat
(equal percentage)

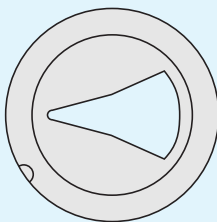

Custom Seats
(special applications)

The relationship between ball position and characterised seat allows for precision throttling control.

The V-Flow control valves are sized to ideally control between 20 - 80% opening of the valve.

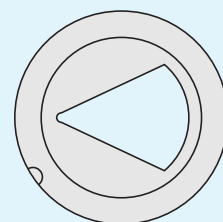

60° Seat
(equal percentage)

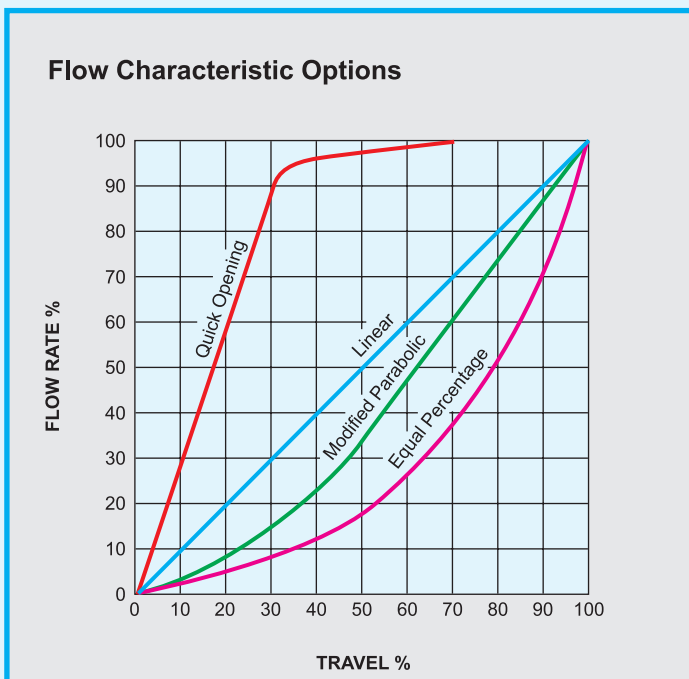

OTHER CRYOGENIC PRODUCTS



C50

The C44 is available up to 50mm. Above this size Worcester offers the C50 one-piece wafer pattern valve for installation between Class 150 and 300 flanges.

For petrochemical requirements the CF51/52 firesafe cryogenic valve is available utilising the same ball and seats as used in the C44 and C50 valves.



CF51/52



DC13

Using the C44 concept for diverting flow, the DC13 is a 90 degree operation valve.

The cryogenic version of our B18 provides a true multi-port design.



CB18



VC44

For control of liquid gases the VC44 valve utilises the profiled metal seat from the proven V-Flow control valve.

For non-continuous cryogenic applications, the CN44 (non-extended) is ideal for drains on cryogenic lines. The valve contains the same ball, seats and body seals as the C44.



CN44



C59

The cryogenic valve is also available as full bore up to 40mm bore for applications where high flow rates are required.

PRESSURE/TEMPERATURE RATINGS

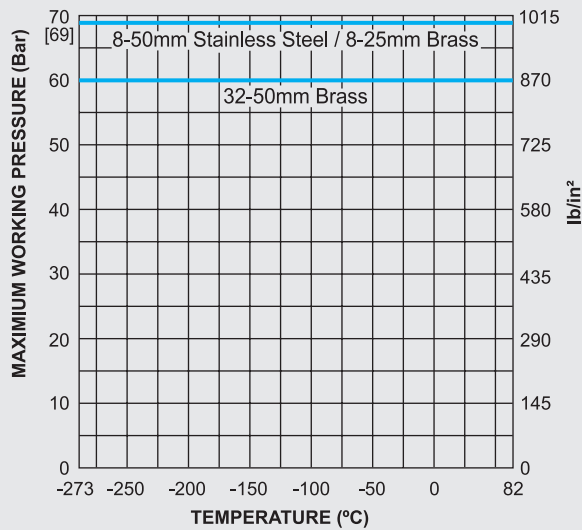

NOTES

1. Screwed ends shown for clarity. Butt weld and socket weld variations are available
2. When wrench not fitted flats on stem when parallel to pipeline axis, denotes ball open.
3. All weld end valves are assembled with 'S' gasket ring body connector seals with additional seals attached loose. This provides for the valve to be tested by Worcester Controls, disassembled by the customer to weld inline, and reassembled-Instructions will be supplied for fitting body seals.
4. All valves that are built in clean room suitable for oxygen service.
5. Installation, Operating and Maintenance Instructions are available on request.

STANDARDS OF COMPLIANCE

Butt Weld Valves	Weld Preparation: SCH 40 & 10: BS 2633 suitable for Schedule Pipe to BS 1600
Socket Weld Valves	Prepared for assembly to plain end pipe in accordance with BS 1600
Screwed Valves	Threaded Specification: BSP Taper - ISO/7 BS21 BSP Parallel - BS 2779/ISO 228/1 ISO/7 (BS 21 DIN 2999) NPT - ANSI B1.20.1
Test Rating	Valves are subjected to the requirements of BS 6755 Pt. 1

TECHNICAL INFORMATION

Valve Size		Flow Coefficients		Equivalent Length of Pipe	
mm	in	Cv	Kv	Feet	Metres
8-15	¼-½	8.3	7.2	1.9	0.58
20	¾	13.6	11.8	5.5	1.67
25	1	37.5	32.6	3.0	0.91
32	1¼	37.7	32.7	4.6	1.4
40	1½	79.5	69.1	3.9	1.19
50	2	106	92	9.0	2.28

Cv – Flow in US GPM Pressure – psi
Kv – Flow in M³/hr Pressure – bar

TYPICAL APPLICATIONS

- Road tankers
 - Terminal unloading stations
 - Food freezing systems
 - High purity cryogenic gas systems
 - Steel production plants
 - LN₂ and CO₂ storage vessels
- and many other services and applications



All valves are built in the clean room and are suitable for oxygen service.



Flowserve Flow Control (UK) Ltd
 Burrell Road, Haywards Heath, West Sussex RH16 1TL
 T: +44 (0)1444 314400 F: +44 (0)1444 314401
 E-mail: wwukinfo@flowserve.com
 Website: www.worcestercontrols.co.uk



Flow Control Division

TM indicates a trade mark of Worcester Controls Information given in this leaflet is made in good faith and based upon specific testing but does not, however, constitute a guarantee